

Primary Isolation - Fugitive Emissions Option

Anderson Greenwood Instrumentation - Primary Isolation Range

Fugitive Emissions compliance to ISO 15848-1 & 2 For Keyblok and Monoflange Product:

TESCOM Anderson Greenwood Instrumentation offers a design portfolio of technical solutions to satisfy ISO15848-1 on fugitive emissions requirements as a part of our Primary Isolation Valve range. These solutions are ideal for Process to Instrument Isolation applications in the Oil and Gas, Process, Refining, Chemical, and Energy markets. The Fugitive Emissions options help serve these industries as they are advancing the requirements for environmental sustainability and enhanced emissions management within their operational assets.

To meet this industry ISO standard, TESCOM Anderson Greenwood Instrumentation is utilising its extensive engineering expertise to provide both ball and needle valve designs across a full range of primary isolation products.

Fugitive Emissions compliant graphite stem packing for design pressure classes up to ANSI 2500 (6000psi) and minimum temperature range down to -57°C (-70°F). The designs are suitable for use within the KeyBlok F & P Series & Monflange HD Series of body configurations.

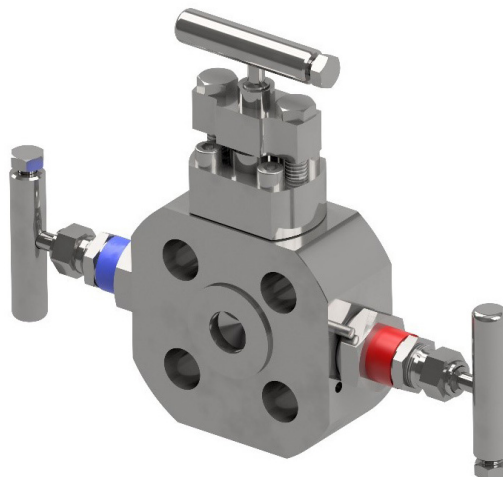

Primary Isolation - Fugitive Emissions Option

Anderson Greenwood Instrumentation - Primary Isolation Range

Ball & Needle Valve Designs for Fugitive Emissions Requirements & Applications

Model code suffix 'FE' for ISO 15848 compliant

HD7 Series – Globe Style Needle valve (suffix : FE)
Screwed Bonnet – Type 'H' Graphite FE Packing

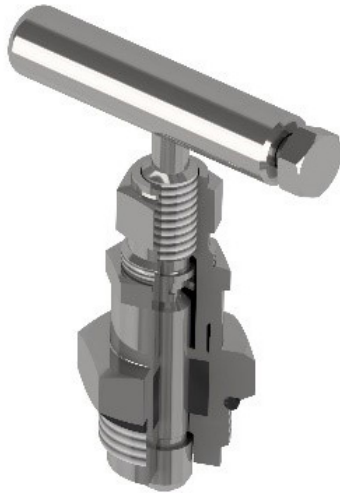

FE HD Series bonnet P/T data (for assemblies)
FE Graphite Type H:

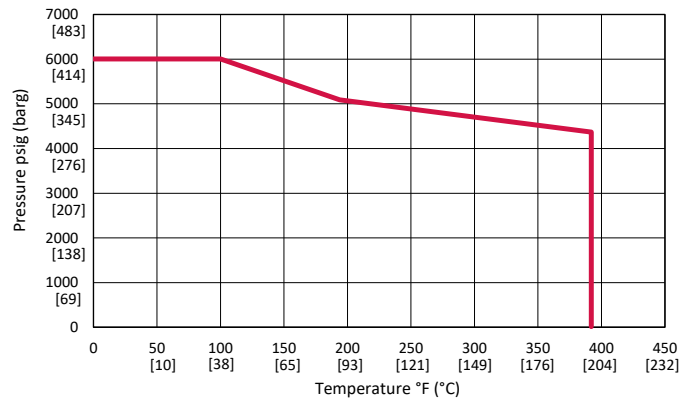

NOTE:

Above mentioned Pressure / Temperature rating is based on 316 Stainless Steel valve assembly with 'FE' option

Features

- 316 Stainless Steel (other materials available)
- Bore Size 5 mm (3/16")
- Integral Valve Seat (globe pattern) – Metal to Metal Seated
- 2-Piece Stem (Nitronic 50 - upper) – helps to prevent stems from galling, improves strength and ease of operation
- Bottom stem 'sliding style' rising stem for improved sealing endurance, free swivel ball end
- Packing below threads – stem threads are protected from process media (non-wetted)
- Back Seat – Metal to Metal / for packing protection
- Color coded for operating function
- Maximum Allowable (Working) Pressure: 413.7 bar (6,000 psi)
- ISO 15848-1:2015 + A1:2017 Helium testing, BH tightness class, CO1 endurance, Temperature (Class T200) 5°C to 200°C (41°F to 392°F), ANSI 2500 – with no stem packing adjustments
- All non-wetted parts in 316 Stainless Steel
- Valve types also comply with the requirements of ASME B16.34, MSS SP99/105
- Certified Fire Safe Design to ISO 10497

Anderson Greenwood Instrumentation - Primary Isolation Range

Ball & Needle Valve Designs for Fugitive Emissions Requirements & Applications

Model code suffix 'FE' for ISO 15848 standard compliant

HD7K Series – Globe Style Needle valve (suffix : FE)
Bolted Bonnet (OS&Y) – Type 'H' FE Graphite Packing

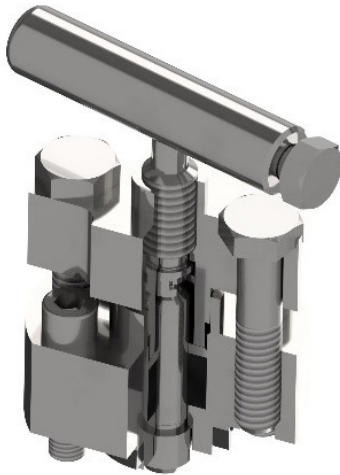

FE HD/OS&Y - Series bonnet P/T data (for assemblies)
FE Graphite Type H:

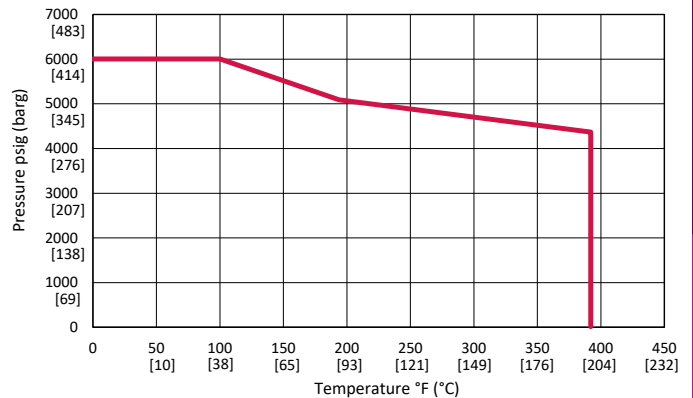

NOTE:

Above mentioned Pressure / Temperature rating is based on 316 Stainless Steel valve assembly with 'FE' option

Features

- 316 Stainless Steel only
- Bore Size 5 mm (3/16")
- Bolted bonnet to body connection with outside screw type stem actuation threads
- 2-piece Stem (Nitronic 50 - upper) – helps to prevent stems from galling, improves strength & ease of operation
- Bottom stem 'sliding style' rising stem for improved sealing endurance, free swivel ball end
- Back Seat – Metal to Metal / for packing protection
- Maximum allowable (Working) Pressure: 413.7 bar (6,000 psi)
- ISO 15848-1:2015 + A1:2017 Helium testing, BH tightness class, CO1 endurance, Temperature (Class T200) 5°C to 200°C (41°F to 392°F), ANSI 2500 – with no stem packing adjustments
- All non-wetted parts in 316 Stainless Steel
- Valve types also comply with the requirements of ASME B31.1, B31.3, B16.34 & MSS SP99/105
- Certified Fire Safe Design to ISO 10497

Primary Isolation - Fugitive Emissions Option

Anderson Greenwood Instrumentation - Primary Isolation Range

Ball & Needle Valve Designs for Fugitive Emissions Requirements & Applications

Model code suffix 'FE' for ISO 15848 compliant

Keyblok Series – 1/4 turn Ball Valve (suffix : FE)
 Ball valve 10mm (3/8”), 14mm (1/2”),
 20mm (3/4”) Bore – Type 'F' & 'P', PEEK seat,
 FE Graphite Packing

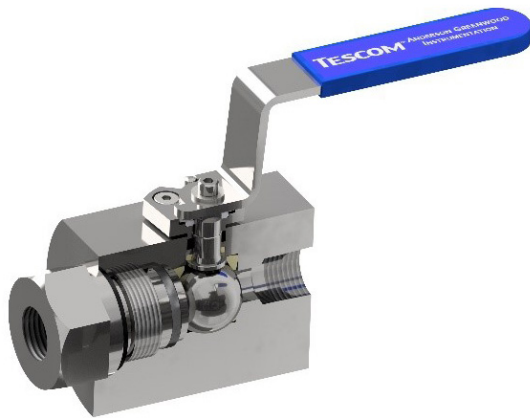

FE Keyblok F & P- Series P/T data (for assemblies) with 'FE' option

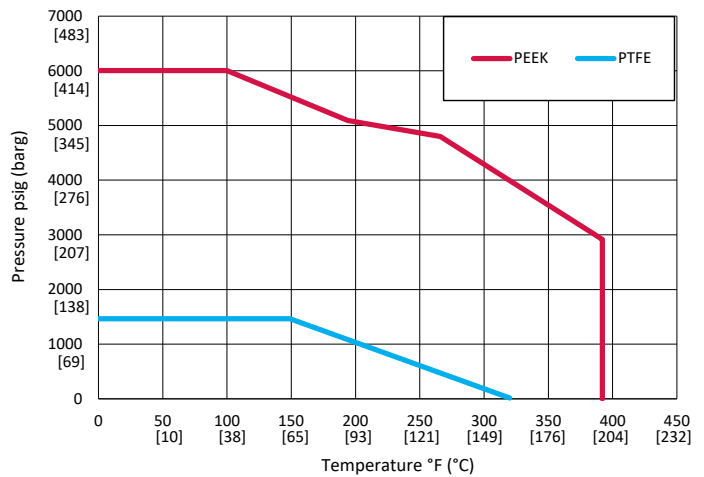

Features

- 316 Stainless Steel (other materials available)
- Bore Size 3/8” (10 mm) – 3/4” (20mm)
- 1/4 Turn stem operation
- Back Seat – Anti-blow out proof stem
- Standard bolted stem packing lock plate – maintains stem packing loading integrity after handle removal
- Valve body seat (Straight through bore) – replaceable soft seat (PEEK)
- Maximum Allowable (Working) Pressure : 400 bar (6,000 psi)
- ISO 15848-1:2015 + A1:2017 Helium testing, BH tightness class, CO1 endurance, Temperature (Class T200) 5°C to 200°C (41°F to 392°F), ANSI 2500 – with no stem packing adjustments
- All non-wetted parts in 316 Stainless Steel
- Valve types also comply with the requirements of EMMUA 182, ASME B31.1, B31.3 & B16.34
- Certified Fire Safe Design to ISO 10497

Anderson Greenwood Instrumentation - Primary Isolation Range

FE option available for the following Product families:

- HD7 Series (globe pattern):
Monoflange HD7M, HD27M, HD33M; Root valves
HD29, F29, F73
- HD7K Series (globe pattern):
Monoflange HD7MK, HD27MK, HD33MK; Root valves
F33K, F73K; Gauge Valves M5K, M5YK
- Keyblok Series (ball valve):
Block / Double Block F7, F66; Block & Bleed F62, P62;
Double Block & Bleed F63, F64, F68, F69, P63

** Availability: FCA Harlingen, Texas

Leadtime: FE option

- Monoflange type ... consult standard global matrix
- Root Valve type ... consult standard global matrix
- Keyblok type ... consult standard global matrix

Email: ordersagip@emerson.com

** Qualification / Certification

- ISO 15848-1 Fugitive Emissions type test in accordance with 3rd Party inspection by Lloyds Register EMEA
- TESCO AGI Standard Functional Test Certification & Certificate of Conformance
- Product testing / certification to ISO15848-2 can be provided on request. Please consult customer service team.